

# 样品承认书

Product Specification

产品名称(Product)	投射式电容触摸屏 Projected Capacitive Touch Screen
编号(Product No.)	55 寸投射式电容触摸屏
客户名称(Client)	
客户编号(Client Part No.)	YFDR0550347
送样日期(Date)	20220812

客户签核 (Client Assignment)			
部门 (Department)	签核 (Assignment)	部门 (Department)	核准 (Approved)
工程部 (Product Department)		工程部 (Product Department)	
品质部 (Quality Department)		品质部 (Quality Department)	
采购部 (Purchasing Department)		业务部 (Sales Department)	
结果 (Result)	<input type="checkbox"/> 合格(Passed) <input type="checkbox"/> 条件批准(AOD) 备注(Remark) <input type="checkbox"/> 不合格, (Feiled) 备注(Remark)		

# 目录(Contents)

1. 修订履历(Revision History) .....	3
2. 应用范围(Application) .....	4
3. 产品特性(Product Features) .....	4
4. 电气结构 (Electrical structure) .....	4
5. 电子特性(Electrical Characteristics) .....	4
6. Pin Assignments/PIN 定义 .....	5
7. 环境特性(Environmental Characteristics) .....	5
8. 光学及机械特性 (Optical and mechanical properties) .....	5
9. 可靠性测试(Reliability Test) .....	5
10. 结构图(Engineer Drawing) .....	6
11. 产品外观标准 (Product appearance standard) .....	7、8
12. 包装及运送(Packaging and shipping) .....	9
13. 组装过程中的注意事项 (Precautions during the assembly) .....	9
14. 样品承认书的反馈(Samples of feedback admit it).....	10



## 2. 应用范围 (Application)

此规格书可应用于投射式电容触摸屏模组。

The specifications are applicable for projected capacitive touch module.

## 3. 产品特性 (Product Features)

类别 (Item)	参数 (Spec.)	备注 (Remarks)
产品结构 (Product structure)	G+G	
AV 尺寸描 (AV dimension description)	55 寸	
可视区尺寸 (V.A. Size)	1208.6×679.4mm (±0.3mm)	
总厚度 (Total Thickness)	5.4mm (±0.2mm)	
外形尺寸 (Outline Dimension)	1260.4×731.2mm (±0.3mm)	
外形圆角 (O.D. Fillet)	4-R9.7	
面板厚度 (Coverlens Thickness)	3.85mm (±0.15mm)	
ITO 玻璃尺寸 (ITO Glass Size)	1251.6×716.4 (±0.5mm)	
ITO 玻璃厚度 (ITO Glass Thickness)	1.1mm (±0.1mm)	

## 4. 电气结构 (Electrical structure)

类别 (Item)	参数 (Spec.)	备注 (Remarks)
检测芯片 (Sensing IC)	ILI 2316C3PIV1	COB
感应器通道数 (Number of Channels)	RX96*TX54	
支持触点 (Support Contact)	20	
触摸按键数 (Number of Touch Keys)	0	
接口形式 (Interface form)	USB	4P*1.25
工作电压 (Work voltage)	5.0V	

## 5. 电子特性 (Electrical Characteristics)

(TA=40 to +70°C Reg in=5.0V unless otherwise specified)

Interface to Host/Master (主机接口)	USB, 4 wire, 2.0 Full speed
Supply Voltage/工作电压	USB 5VDC
Oscillator Frequency/振荡频率	12MHz
Support Points/支持点数	Multi-finger
Min. Report Rate/读取速度	100points/sec (Target, Need formal test report)

## 6. Pin Assignments/PIN 定义

USB	Name/名称	Type/类型	Description/说明
1	GND	GND	Ground
2	DM	Signal	USB D- Signal
3	DP	Signal	USB D+ Signal
4	VDD	VDD 5V DC	Supply Voltage

## 7. 环境特性 (Environmental Characteristics)

类别 (Item)	温度 (Temperature)	湿度 (Humidity)
操作 (Operating)	-10~60°C	20%RH~90%RH
储藏 (Storage)	-20~70°C	10%RH~90%RH

## 8. 光学及机械特性(Optical and mechanical properties)

类别(Item)	参数(Spec.)	备注(Remarks)
透光率(Transparency)	≥85%	
雾度(Haze)	≤3%	
表面硬度(Surface hardness)	>6H	
落球(Falling ball)	≥50cm, 64g 钢球 ≥50cm, 64g steel ball	

## 9. 可靠性测试(Reliability Test)

类别(Item)	条件(Condition)	要求(Requirement)
高温高湿测试 (Hightemperaturehumidity)	温度 60℃, 湿度 90%RH, 时间 96H Temperature 60℃, humidity 90%RH, time 96H	测试完成后, 常温放置 24H, 测试品无缩胶、分层、气泡等现象, 电性测试无异常 After the test is completed, Place at room temperature for 24h, There is no shrinkage, elamination, bubbles and other phenomena in the test article, No abnormality in electrical test
高温存储测试 (High temperature storage)	温度 70℃, 时间 96H Temperature 70℃, time 96H	
低温存储测试 (Low temperature storage)	温度 -30℃, 时间 96H Temperature -30℃, time 96H	
高低温冲击测试 (High and low temperature Impact)	低温 -30℃ 高温 70℃, 每循环 30 分钟, 30 个循环 Low temperature -30℃ High temperature 70℃, 30 minutes per cycle, 30 cycles	
ESD 要求	+/-8KV(空气); +/-4KV(接触) +/-8KV(air); +/-4KV(Contact)	需用客户端整机测试 Client machine test is required

## 10. 结构图(Engineer Drawing)

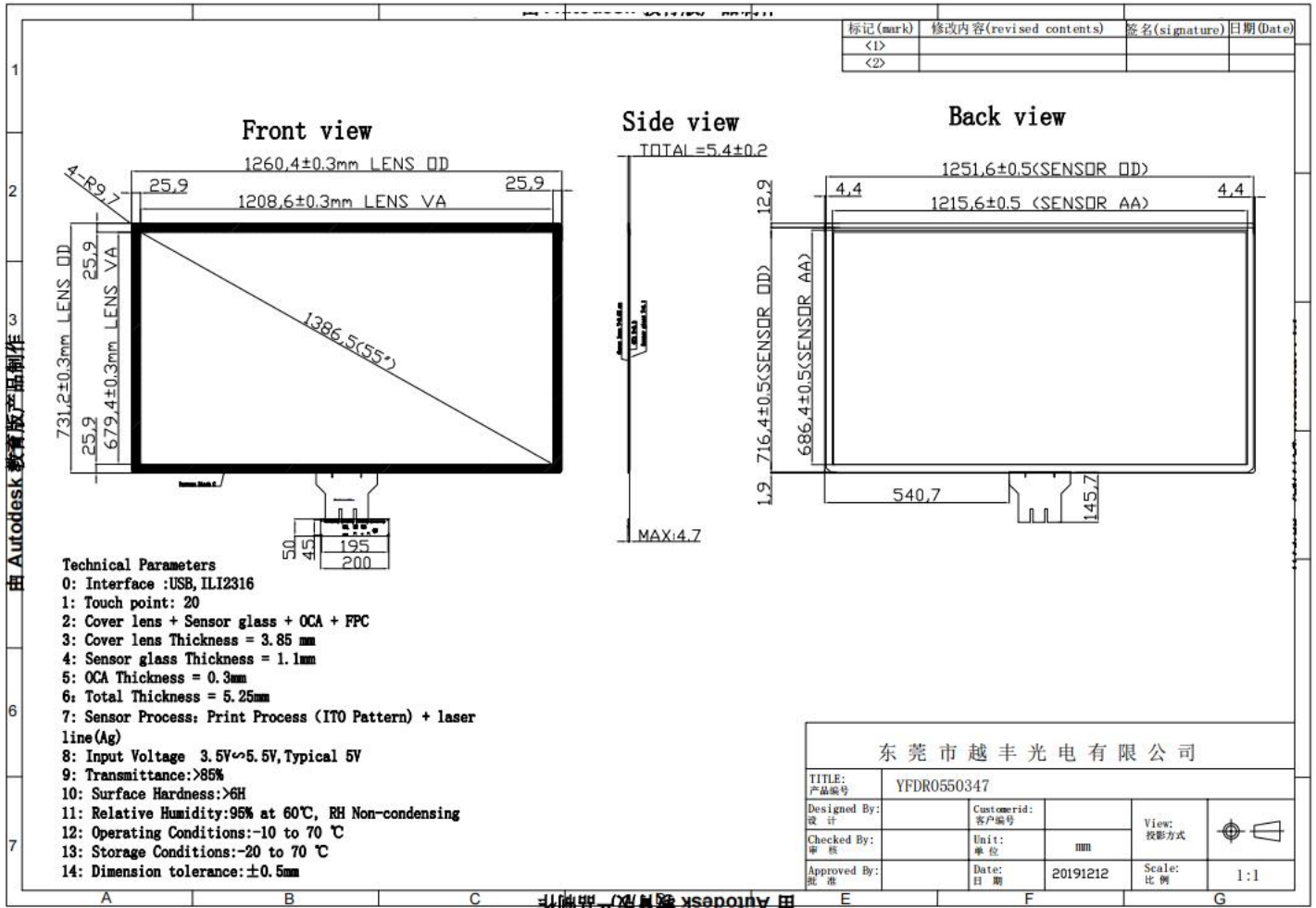

## 11. 产品外观标准(Product appearance standard)

### 11.1 检测条件 (Test environment) :

检测环境条件(Inspection Conditions):	要求 (Requirement) :
洁净度(Cleanliness):	Better than 1000
环境温度(Temperature):	25±5°C
环境湿度(Humidity):	55±10% RH
检验场所亮度(Brightness):	≥800-1000 Lux
光源 (Light Source):	荧光灯 (florescent lamp)
检查观看距离(Inspection Distance):	50±10cm
检查视角(Visible Angle):	90±45°
检验时间(Inspection time):	3-5s
检验时间(Inspection time):	反射光 (reflected light)

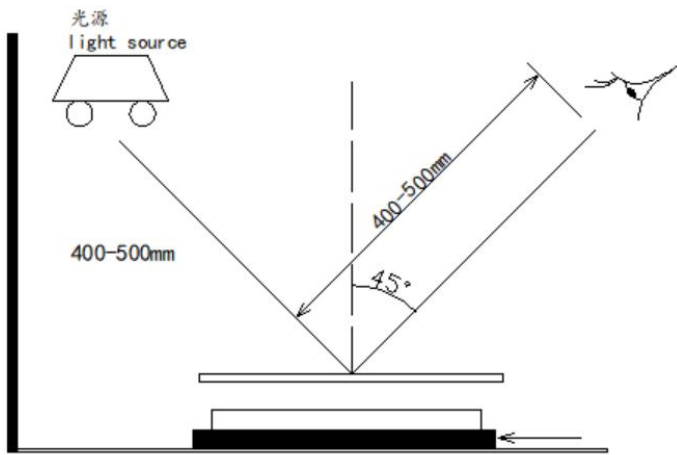

点线缺陷（凹凸点、气泡、污点、划伤、毛发）若缺陷长为宽的 2.5 倍以上，则视为划痕和 线状缺陷，点大小  $D$  计算： $(X+Y)/2$ =点大小。

Dot and line defects (bumps, bubbles, stains, scratches, hair) are considered scratches and linear defects if the length of the defect is more than 2.5 times the width, and the dot size  $D$  is calculated as  $(X+Y)/2$ =dot size.

### 11.2 标准要求 (Standard requirements) :

黑白点 Black/white spot	$D \leq 0.30\text{mm}$ , 不允许密集	Ignored	
	$0.30 < D \leq 0.40\text{mm}$ ; $DS > 15\text{mm}$	$N \leq 5$	
	$0.40 < D \leq 0.50\text{mm}$ , $DS > 15\text{mm}$	$N \leq 3$	
	$D > 0.50\text{mm}$	NG	
刮伤 Scratch	$W \leq 0.1\text{mm}$	Ignored	
	$0.1 \text{ mm} < W \leq 0.25\text{mm}$ ; $L \leq 50\text{mm}$ ; $DS > 20\text{mm}$	$N \leq 4$	
	$0.25\text{mm} < W \leq 0.35\text{mm}$ ; $L \leq 50\text{mm}$ ; $DS > 20\text{mm}$	$N \leq 2$	
	$0.35\text{mm} < W \leq 0.45\text{mm}$ ; $L \leq 50\text{mm}$	$N \leq 1$	
	$W > 0.45\text{mm}$	NG	
气泡/凹凸点/鱼眼/树枝状气泡 Bubble/fish eye	$D \leq 0.2\text{mm}$ , 不允许密集	Ignored	
	$0.2\text{mm} < D \leq 0.4\text{mm}$ ; $DS > 15\text{mm}$	$N \leq 5$	
	$0.4\text{mm} < D \leq 0.5\text{mm}$ , $DS > 15\text{mm}$	$N \leq 3$	
	$D > 0.5\text{mm}$	NG	
裂纹 Crack	NOT allowed		
ITO 缺角, 非面板 ITO Corner Fragment	$X < 3\text{mm}$ , $Y < 2\text{mm}$ , $Z < 0.3\text{mm}$ 且无功能性问题 (Function is OK.)		

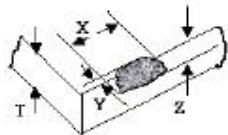
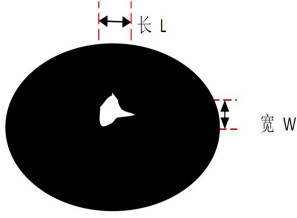
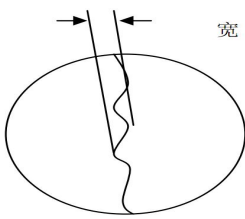
ITO 崩边, 非面板 ITO Side Fragment	$X < 3\text{mm}, Y < 2\text{mm}, Z < 1\text{mm}$ 且无功能性问题 (Function is OK.)		
Coverlens Fragment	Not allowed		
丝印针孔(透光) Pin Hole	$\text{Area} \leq 0.10\text{mm}^2$	$N \leq 4$	
	$\text{Area} \leq 0.6\text{mm}^2$	$N \leq 2$	
丝印锯齿 SilkPrinting Sawtooth	$W \leq 0.2\text{mm}$	Ignored	
	$W \leq 0.25\text{mm}; L \leq 20\text{mm}, DS > 20\text{mm}$	$N \leq 5$	
	$W \leq 0.35\text{mm}; L \leq 20\text{mm}, DS > 20\text{mm}$	$N \leq 3$	
	$W > 0.35\text{mm}$	NG	

## 说明 (Remark):

1. 可以用风吹离和简单擦除掉的外来物, 不视为缺陷。  
It is not the defect that the dust from the environment.
2. 经组装生产过后, 拆卸造成损伤之外观不良, 不视为缺陷。  
It is not the defect that the damage caused by teardown.

## 12. 包装及运送 (Packaging and shipping)

### 12.1 包装、标识 (Packaging, marking)

12.1.1 要求包装方式恰当, 能对产品起到应有的保护, 且利于客户使用。

It is required that the packaging method is appropriate, which can protect the product as well as facilitate the use of customers.

12.1.2 内、外包装标签必须包含: 型号规格、数量、生产日期等。

The inner and outer packaging labels must include: model, specification, quantity, production date, etc.

12.1.3 内外包装张贴ROHS 符合标签, 客户有要求附带《出货检验报告》时, 必须在附报告的外包装箱上注明。

ROHS compliance label shall be pasted on the inner and outer packaging. If the customer requires to attach the Shipping Inspection Report, it must be indicated on the outer packaging box with the report.

### 12.2 运送要求 (Transport)

12.2.1 避免产品直接暴露在阳光直射下及暴露雨水中运输。

Avoid direct exposure of the product to direct sunlight and rain for transportation

12.2.2 货物装车时, 不可将包装箱挤压变形。

When loading the goods, the packing box shall not be squeezed and deformed.

## 13. 组装过程中注意事项 (Precautions during the assembly)



### 13.1 储存的注意事项 Cautions for Storage

储存产品时须按样品承认书的温湿度要求放置，注意不可受日光直射或重物重压。

When storing the product, it is necessary to store it according to the temperature and humidity requirements of the sample acknowledgement, and be careful not to be exposed to direct sunlight or heavy loads

### 13.2 搬运的注意事项 Cautions for unpacking

13.2.1 尽量减少搬运次数。

Minimize handling times.

13.2.2 尽量使用搬运工具。

Use handling tools as much as possible.

13.2.3 堆放不能超过三层，轻拿轻放，向上放置。

Stacking shall not exceed three layers. Handle with care and place upwards.

### 13.3 装配注意事项 Assembly precautions

13.3.1 不要对产品施加额外的拉力。

Do not apply extra tension to the product.

13.3.2 须保持产品的透明清晰度，请在接触产品之前戴上指套或手套。请注意玻璃边角部位。

The clarity of the product must be maintained. Please wear fingertips or gloves before touching the product. Please pay attention to the glass corners.

13.3.3 当拿取产品时，请不要提拉FPC，不可单手拿握产品边角部分，因为此边角位受力过大，易造成产品气泡及分层。

When picking up the product, please do not lift or pull the FPC, and do not hold the corners of the product with one hand, as excessive stress on these corners can easily cause product bubbles and delamination.

13.3.4 安装组合时，请不要重拉FPC，因为重拉将使FPC 从产品上剥离。

When installing the assembly, do not pull the FPC again, because pulling again will peel the FPC from the product.

13.3.5 请不要从侧边使力拉FPC，因为侧边给的拉力会使FPC 破裂。

Please do not pull the FPC from the side, because the pull from the side will break the FPC.

13.3.6 在生产中请注意静电的防护，以免将产品损伤。

Please pay attention to the protection of static electricity during production to avoid damaging the product.

## 14. 样品承认书的反馈 (Samples of feedback admit it)

14.1 此样品承认书只为产品的品质保障。实际上机使用，请检查和评估我司产品与贵司机器设备的配置状况。

This sample acknowledgement is only for product quality assurance. Please check and evaluate the configuration of our products and your machines and equipment for actual use.

14.2 当贵司评估后，请贵司在我司的确认书上盖上确认图章，并且将附本寄回我司，倘若在量产前副本或承认样品未达到我司，我们将默认贵司承认了我司的样品及承认书。

After your evaluation, please affix the confirmation stamp on our confirmation letter and send the attached copy back to us. If the copy or the sample does not reach our company before mass production, we will acquiesce that your company has accepted our sample and the confirmation letter

14.3 样品承认书变更内容需针对实际情况进行协商变更，需重新更新承认书。

The content of the sample acknowledgement shall be changed through negotiation according to the actual situation, and the acknowledgement shall be renewed.